

3200

PID Temperature
controllers



User Guide



Manuel Utilisateur



Bedienungsanleitung



Invensys

EUROTHERM

This booklet includes:

User Guide (HA028582 Issue 6)

Manuel Utilisateur (HA028582FRA Indice 6)

Bedienungsanleitung (HA028582GER Ausgabe 5)

3200 Series PID Temperature Controllers

Applies to Model numbers 3216, 3208, 32h8 and 3204

Contents

1.	What Instrument Do I Have?	4
1.1	Unpacking Your Controller	4
1.2	Dimensions.....	5
1.3	Step 1: Installation	7
1.3.1	Panel Mounting the Controller.....	7
1.3.2	Panel Cut-out Sizes.....	7
1.3.3	Recommended minimum spacing of controllers. Applies to all Model sizes.....	8
1.3.4	To Remove the Controller from its Sleeve	8
1.4	Ordering Code	9
2.	Step 2: Wiring	10
2.1	Terminal Layout 3216 Controller.....	10
2.2	Terminal Layout 3208 and 3204 Controllers	11
2.3	Terminal Layout 32h8 Controller	12
2.4	Wire Sizes	13
2.5	Sensor Input (Measuring Input)	13
2.6	Input/Output 1 & Output 2	14
2.7	Remote Setpoint Input.....	15

2.8	Output 3	15
2.9	Output 4 (AA Relay)	16
2.10	Digital Inputs A & B	17
2.11	Transmitter Power Supply	17
2.12	Current Transformer	18
2.13	Digital Communications	19
2.14	Controller Power Supply.....	21
2.15	Example Wiring Diagram	21
3.	Safety and EMC Information	22
3.1	Installation Safety Requirements.....	23
4.	Switch On	27
4.1	Initial Configuration	27
4.2	To Re-Enter Quick Code configuration mode	30
4.3	Pre-Configured Controller or Subsequent Starts	30
4.4	Front panel layout.....	31
4.4.1	To Set The Target Temperature (setpoint).....	32
4.4.2	Alarm Indication	32
4.4.3	Auto, Manual and Off Mode.....	32
4.4.4	To Select Auto, Manual or OFF Mode	33
4.4.5	Operator Parameters in Level 1	34
5.	Operator Level 2	35
5.1	To Enter Level 2.....	35
5.2	To Return to Level 1	35
5.3	Level 2 Parameters	35

5.4	Timer Operation	44
5.5	Dwell Timer	45
5.6	Delayed Timer	46
5.7	Soft Start Timer	47
5.8	Programmer	48
5.8.1	Programmer Servo Mode and Power Cycling.....	49
5.8.2	To Operate the Programmer.....	50
5.8.3	To Configure the Programmer	51
	Restriction of Harzardous Substances Statement(RoHS)	54

Issue 5 of this User Guide applies to software versions 2.09 and above for PID controller and 2.29 and above for Valve Position controllers.

Issue 5 of this User Guide includes:-

- Remote Setpoint Input Option RCL
- Programmer Cycles
- EIA422 4-wire Digital Communications, Option 6XX available in 3216 only

Issue 6 of this User Guide applies to firmware versions 2.11 and above for PID controller and 2.21 and above for Valve Position controllers.

Issue 6 includes additional parameters.

Installation and Basic Operation

1. What Instrument Do I Have?

Thank you for choosing this 3200 series Temperature Controller/Programmer.

The 3200 series provide precise temperature control of industrial processes and is available in three standard DIN sizes:-

- 1/16 DIN Model Number 3216
- 1/8 DIN Model Number 3208
- 1/8 DIN Horizontal Model Number 32h8
- 1/4 DIN Model Number 3204

A universal input accepts various thermocouples, RTDs or process inputs. Up to three (3216) or four (3208, 32h8 and 3204) outputs can be configured for control, alarm or re-transmission purposes. Digital communications and a current transformer input are available as options.

The controller may have been ordered to a hardware code only or pre-configured using an optional 'Quick Start' code. The label fitted to the side of the sleeve shows the ordering code that the controller was supplied to. The last two sets of five digits show the Quick Code. If the Quick Code shows *****/*****

the controller will need to be configured when it is first switched on.

This User Guide takes you through step by step instructions to help you to install, wire, configure and use the controller. For features not covered in this User Guide, a detailed Engineering Manual, Part No HA027986, and other related handbooks can be downloaded from www.eurotherm.co.uk.

1.1 Unpacking Your Controller

The following items are included in the box:

- Controller mounted in its sleeve
- Two panel retaining clips
- AN IP65 sealing gasket mounted on the sleeve
- Component packet containing a snubber for each relay output and a 2.49Ω resistor for current inputs (see section 2)
- This User Guide

1.2 Dimensions

The following two pages show general views of the controllers together with overall dimensions.

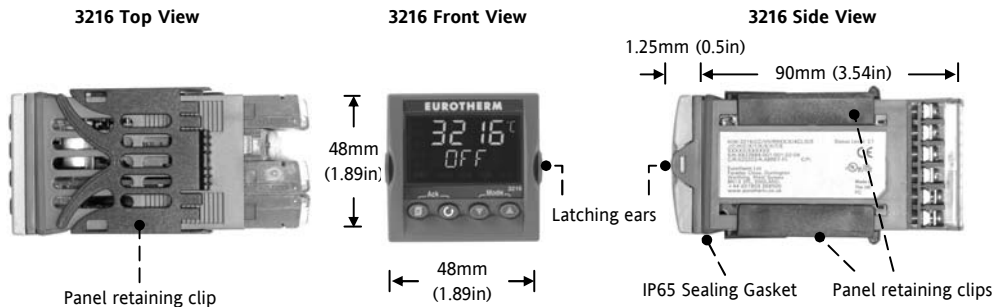

3208 Front



32h8 Front



3204 Front



32h8 Side with Panel Retaining Clips



3208 Top with Panel Retaining Clip

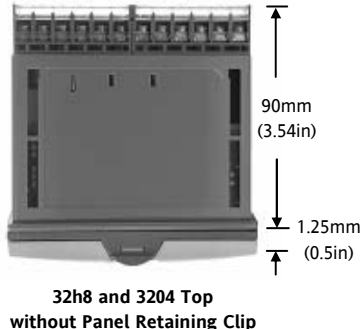
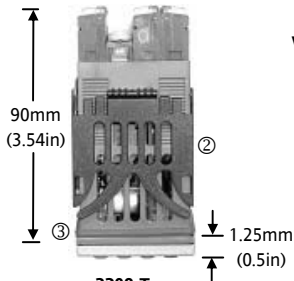

32h8 and 3204 Top without Panel Retaining Clip

1.3 Step 1: Installation

This controller is intended for permanent installation, for indoor use only, and enclosed in an electrical panel

Select a location which is subject to minimum vibrations, the ambient temperature is within 0 and 55°C (32 - 131°F) and humidity 5 to 95% RH non condensing.

The controller can be mounted on a panel up to 15mm thick

To ensure IP65 and NEMA 4 front sealing against dust and water, mount on a non-textured surface.

Please read the safety information in section 3 before proceeding. The EMC Booklet part number HA025464 gives further installation information.

1.3.1 Panel Mounting the Controller

1. Prepare a cut-out in the mounting panel to the size shown. If a number of controllers are to be mounted in the same panel observe the minimum spacing shown.
2. Fit the IP65 sealing gasket behind the front bezel of the controller
3. Insert the controller through the cut-out

4. Spring the panel retaining clips into place. Secure the controller in position by holding it level and pushing both retaining clips forward.
5. Peel off the protective cover from the display

1.3.2 Panel Cut-out Sizes

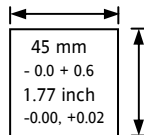

1/16 DIN Cut Out

45 mm - 0.0 + 0.6
1.77 inch -0.00, +0.02

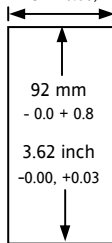

1/8 DIN Cut Out

92 mm - 0.0 + 0.8
3.62 inch -0.00, +0.03

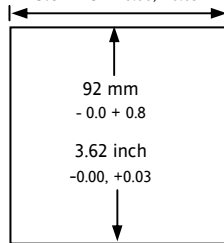

1/4 DIN Cut Out

1.3.3 Recommended minimum spacing of controllers.

Applies to all Model sizes

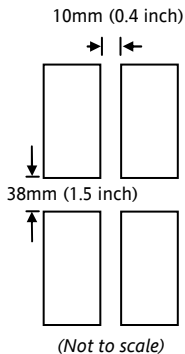

1.3.4 To Remove the Controller from its Sleeve

The controller can be unplugged from its sleeve by easing the latching ears outwards and pulling it forward out of the sleeve. When plugging it back into its sleeve, ensure that the latching ears click back into place to maintain the IP65 sealing.

2. Step 2: Wiring

2.1 Terminal Layout 3216 Controller

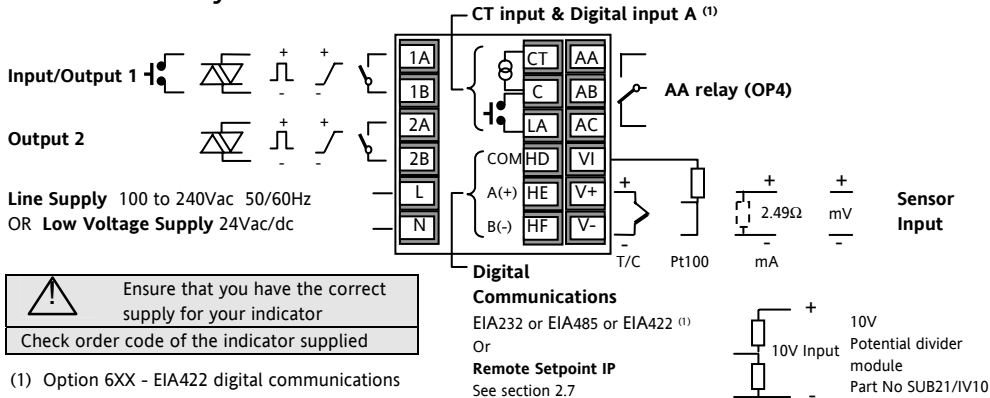

Ensure that you have the correct supply for your indicator

Check order code of the indicator supplied

(1) Option 6XX - EIA422 digital communications uses terminals CT to HF.

CT/LA inputs are not available see section 2.10

Key to symbols used in this and following wiring diagrams

	Logic (SSR drive) output		Relay output		Contact input
	mA analogue output		Triac output		Current transformer input

2.2 Terminal Layout 3208 and 3204 Controllers

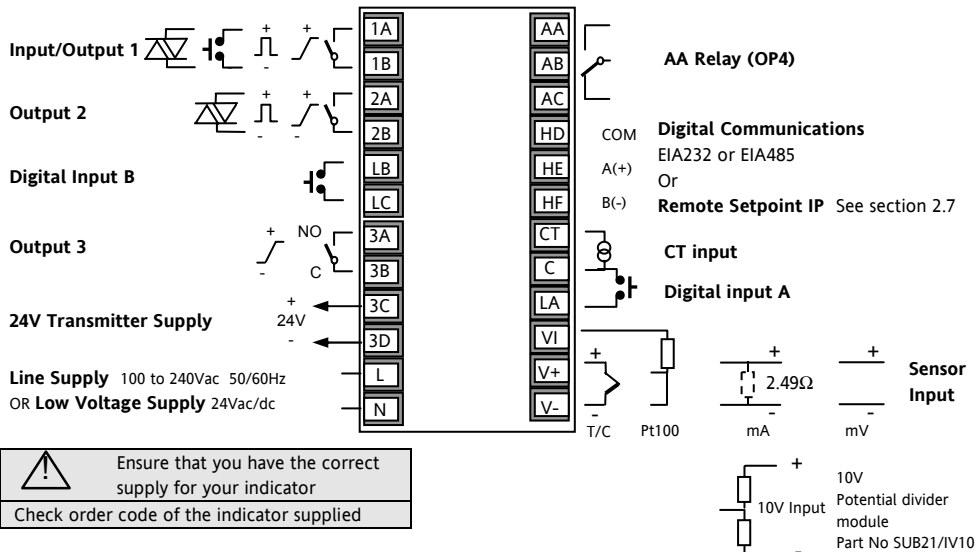

2.3 Terminal Layout 32h8 Controller

	Ensure that you have the correct supply for your indicator
Check order code of the indicator supplied	

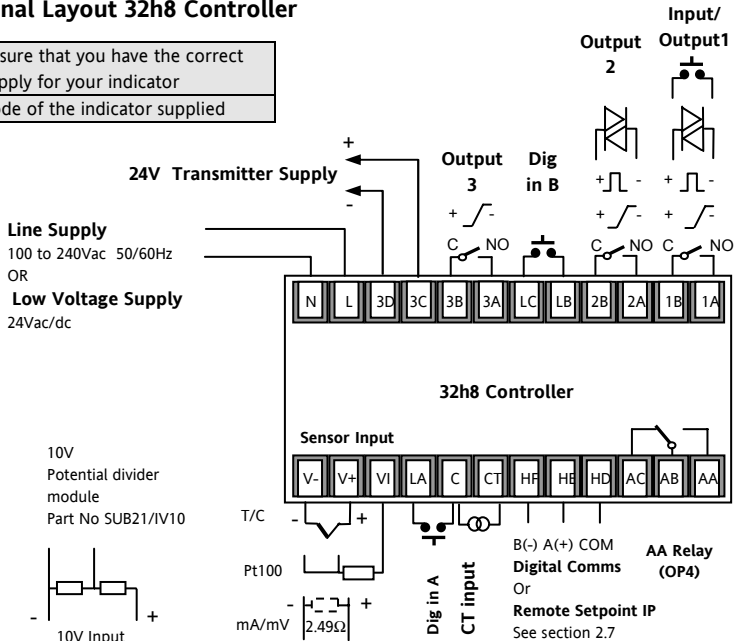

2.4 Wire Sizes

The screw terminals accept wire sizes from 0.5 to 1.5 mm (16 to 22AWG). Hinged covers prevent hands or metal making accidental contact with live wires. The rear terminal screws should be tightened to 0.4Nm (3.5lb in).

2.5 Sensor Input (Measuring Input)

- Do not run input wires with power cables
- When shielded cable is used, it should be grounded at one point only
- Any external components (such as zener barriers) connected between sensor and input terminals may cause errors in measurement due to excessive and/or un-balanced line resistance, or leakage currents.
- Not isolated from the logic outputs & digital inputs

Thermocouple Input

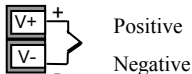

- Use the correct compensating cable preferably shielded.

RTD Input

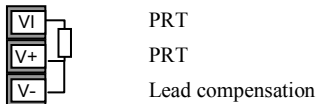

- The resistance of the three wires must be the same. The line resistance may cause errors if it exceeds 22Ω.

Linear mA, mV or Voltage Inputs

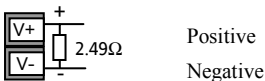

- For a mA input connect the 2.49Ω burden resistor supplied between the V+ and V- terminals as shown
- For a 0-10Vdc input an external input adaptor is required (not supplied). Part number: SUB21/IV10.

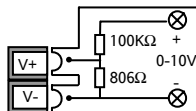

With this adaptor fitted sensor break alarm does not operate.

2.6 Input/Output 1 & Output 2

May be configured as input or output.

Outputs can be logic (SSR drive), or relay, or mA dc.

Input is contact closure.

Relay Output (Form A, normally open)

OP1/2



- Isolated output 240Vac CATII
- Contact rating: 2A 264Vac resistive
- Output functions: Heating, or cooling, or alarm or motorised valve open or closed

Logic (SSR drive) Output

OP1/2

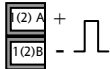

- Not isolated from the sensor input
- Output ON state: 12Vdc at 40mA max
- Output OFF state: <300mV, <100µA
- Output functions: Heating, or cooling, or alarm or motorised valve open or closed
- The output switching rate must be set to prevent damage to the output device in use. See parameter 1.PLS or 2.PLS in section 5.3

DC Output

OP1/2

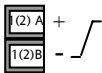

- Not isolated from the sensor input
- Software configurable: 0-20mA or 4-20mA.
- Max load resistance: 500Ω
- Calibration accuracy: \pm (<1% of reading + <100µA)
- Output functions: Heating, or cooling, or retransmission.

Triac Output

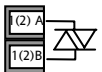

- Isolated output 240Vac CATII
Rating: 0.75A rms, 30 to 264Vac resistive

Logic Contact Closure Input (OP1 only)

OP1



- Not isolated from the sensor input
- Switching: 12Vdc at 40mA max
- Contact open > 500Ω. Contact closed < 150Ω
- Input functions: Please refer to the list in the Quick Start codes.

2.7 Remote Setpoint Input

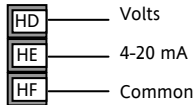

- There are two inputs; 4-20mA and Volts which can be fitted in place of digital communications
- It is not necessary to fit an external burden

resistor to the 4-20mA input

- If the 4-20mA remote setpoint input is connected and valid ($>3.5\text{mA}$; $<22\text{mA}$) it will be used as the main setpoint. If it is not valid or not connected the controller will try to use the Volts input. Volts sensor break occurs at <-1 ; $>+11\text{V}$. The two inputs are not isolated from each other
- If neither remote input is valid the controller will fall back to the internal setpoint, SP1 or SP2 and flash the alarm beacon. The alarm can also activate a relay if configured or read over digital communications. See Engineering Handbook HA027986
- To calibrate the remote setpoint, if required, see the Engineering Handbook HA027986
- A local SP trim value is available in a deeper level of access. See Engineering Handbook HA027986

2.8 Output 3

Output 3 is not available in model 3216. In 1/8 and 1/4 DIN controllers it is either a relay or a mA output.

Relay Output (Form A, normally open)

OP3



- Isolated output 240Vac CATII
- Contact rating: 2A 264Vac resistive
- Output functions: Heating, or cooling, or alarm or motorised valve open or closed

DC Output

OP3

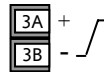

- Isolated output 240Vac CATII
- Software configurable: 0-20mA or 4-20mA
- Max load resistance: 500 Ω
- Calibration accuracy: $\pm(<0.25\%$ of reading + $<50\mu\text{A}$)
- Output functions: Heating, or cooling, or retransmission.

2.9 Output 4 (AA Relay)

Output 4 is always a relay.

Relay Output (Form C)

OP4

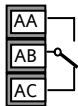

- Isolated output 240Vac CATII
- Contact rating: 2A 264Vac resistive
- Output functions: Heating, or cooling, or alarm or motorised valve open or closed

* General Notes about Relays and Inductive Loads

High voltage transients may occur when switching inductive loads such as some contactors or solenoid valves. Through the internal contacts, these transients may introduce disturbances which could affect the performance of the instrument.

For this type of load it is recommended that a 'snubber' is connected across the normally open contact of the relay switching the load. The snubber recommended consists of a series connected resistor/capacitor (typically 15nF/100Ω). A snubber will also prolong the life of the relay contacts.

A snubber should also be connected across the output terminal of a triac output to prevent false triggering under line transient conditions.

WARNING

When the relay contact is open, or it is connected to a high impedance load, it passes a current (typically 0.6mA at 110Vac and 1.2mA at 240Vac). You must ensure that this current will not hold on low power electrical loads. If the load is of this type the snubber should not be connected.

2.10 Digital Inputs A & B

Digital input A is an optional input in all Model sizes.
Digital input B is always fitted in the Models 3208, 32h8 and 3204.

Dig in A



Dig in B



- Not isolated from the current transformer input or the sensor input
- Switching: 12Vdc at 40mA max
- Contact open > 500Ω. Contact closed < 200Ω
- Input functions: Please refer to the list in the quick codes.

☺ If EIA422 digital communications is fitted, Digital Input A is not available.

2.11 Transmitter Power Supply

The Transmitter Supply is not available in the Model 3216. It is fitted as standard in the Models 3208 and 3204.

Transmitter Supply

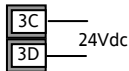

- Isolated output 240Vac CATII
- Output: 24Vdc, +/- 10%. 28mA max.

2.12 Current Transformer

The current transformer input is an optional input in all model sizes.

It can be connected to monitor the rms current in an electrical load and to provide load diagnostics. The following fault conditions can be detected: SSR (solid state relay) short circuit, heater open circuit and partial load failure. These faults are displayed as alarm messages on the controller front panel.

☺ If EIA422 digital communications is fitted, Current Transformer Input is not available.

CT Input



Note: Terminal C is common to both the CT input and Digital input A. They are, therefore, not isolated from each other or the PV input.

- CT input current: 0-50mA rms (sine wave, calibrated) 50/60Hz
- A burden resistor, value 10Ω , is fitted inside the controller.
- It is recommended that the current transformer is fitted with a voltage limiting device to prevent high voltage transients if the controller is unplugged. For example, two back to back zener diodes. The zener voltage should be between 3 and 10V, rated at 50mA.
- CT input resolution: 0.1A for scale up to 10A, 1A for scale 11 to 100A
- CT input accuracy: $\pm 4\%$ of reading.

